

MIKRO-PULSAIRE® DUST COLLECTORS

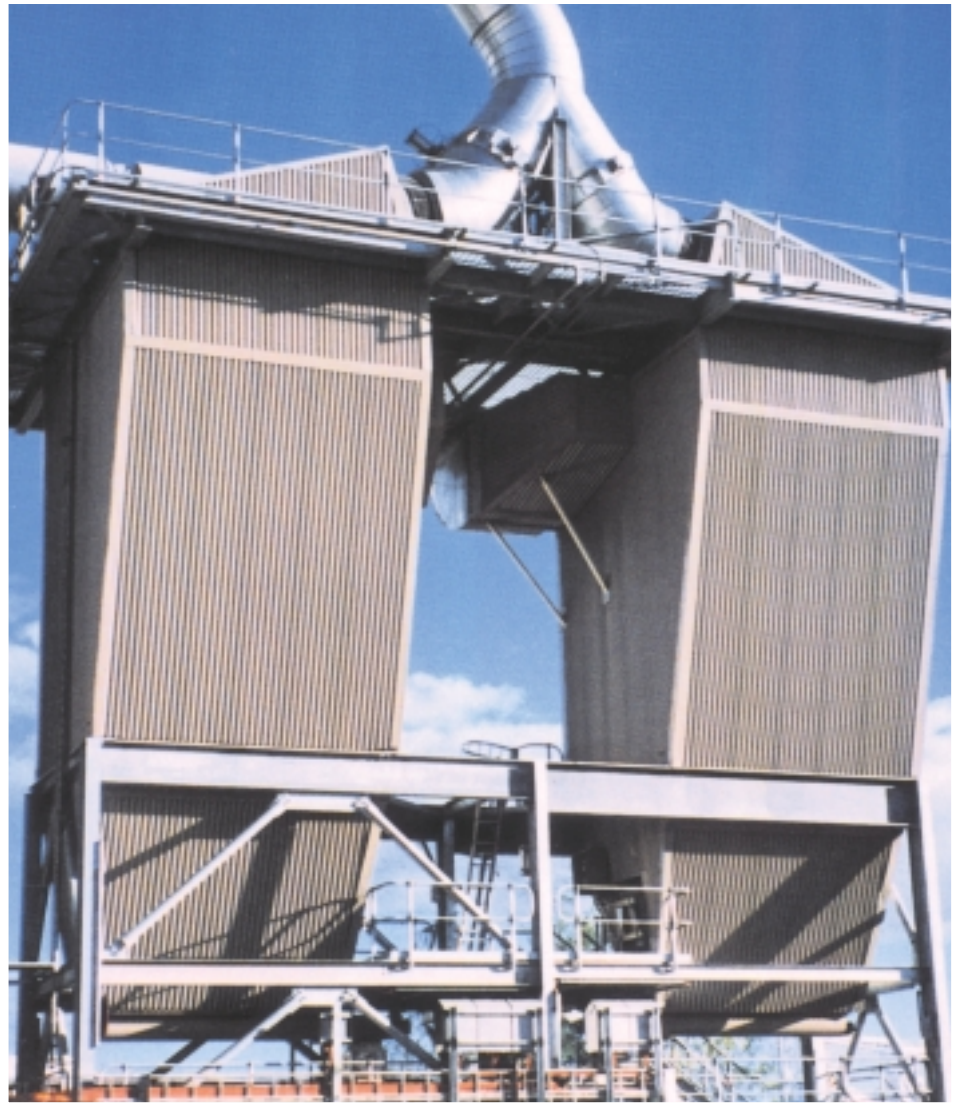

MIKROPUL

DRY FILTRATION
WET SCRUBBERS
CYCLONES
WET ELECTROSTATIC
PRECIPITATORS

MIKRO-PULSAIRE® DUST COLLECTOR

MikroPul invented the first pulse-jet dust collector in 1956 and has since installed more than 160.000 systems. Our extensive experience has created a comprehensive application database, allowing us to recommend the best, proven solution for your dust control needs.

How The Mikro-Pulsaire Works

The dust-tight Pulsaire has three sections: a clean-air plenum at the top, a filtration housing containing a number of cylindrical filter bags in the middle, and a dust inlet/discharge hopper at the bottom. The filter bags are supported from a tube sheet which separates the filtration housing from the plenum.

Dust laden air enters the collector through a diffuser (1) which absorbs the impact of the high velocity dust particles, distributes the air, and reduces its velocity. The slower air speed causes the heavier particles to drop into the hopper. The air stream then flows through the filter bags (2), depositing the fine dust on the outside of the bag. The cleaned air continues upward into the plenum and exhausts into the atmosphere (3).

Filter bags are cleaned by a momentary, high pressure back-pulse of compressed air from the clean side of the bag. The pulses are delivered by blowpipes (4), arranged over each row of bags, incorporating orifice nozzles directed into the center of each bag. The bursts of air are optimized by venturis located at the top of the bags to effectively dislodge dust along the length of the bag.

Cleaning cycles are timed by a Mikro-Pul solid state 10-position timer. A differential pressure (between the clean and dirty sides) gauge helps determine cleaning frequency.

Shown with optional walk-in plenum, ladder, platform, and support legs

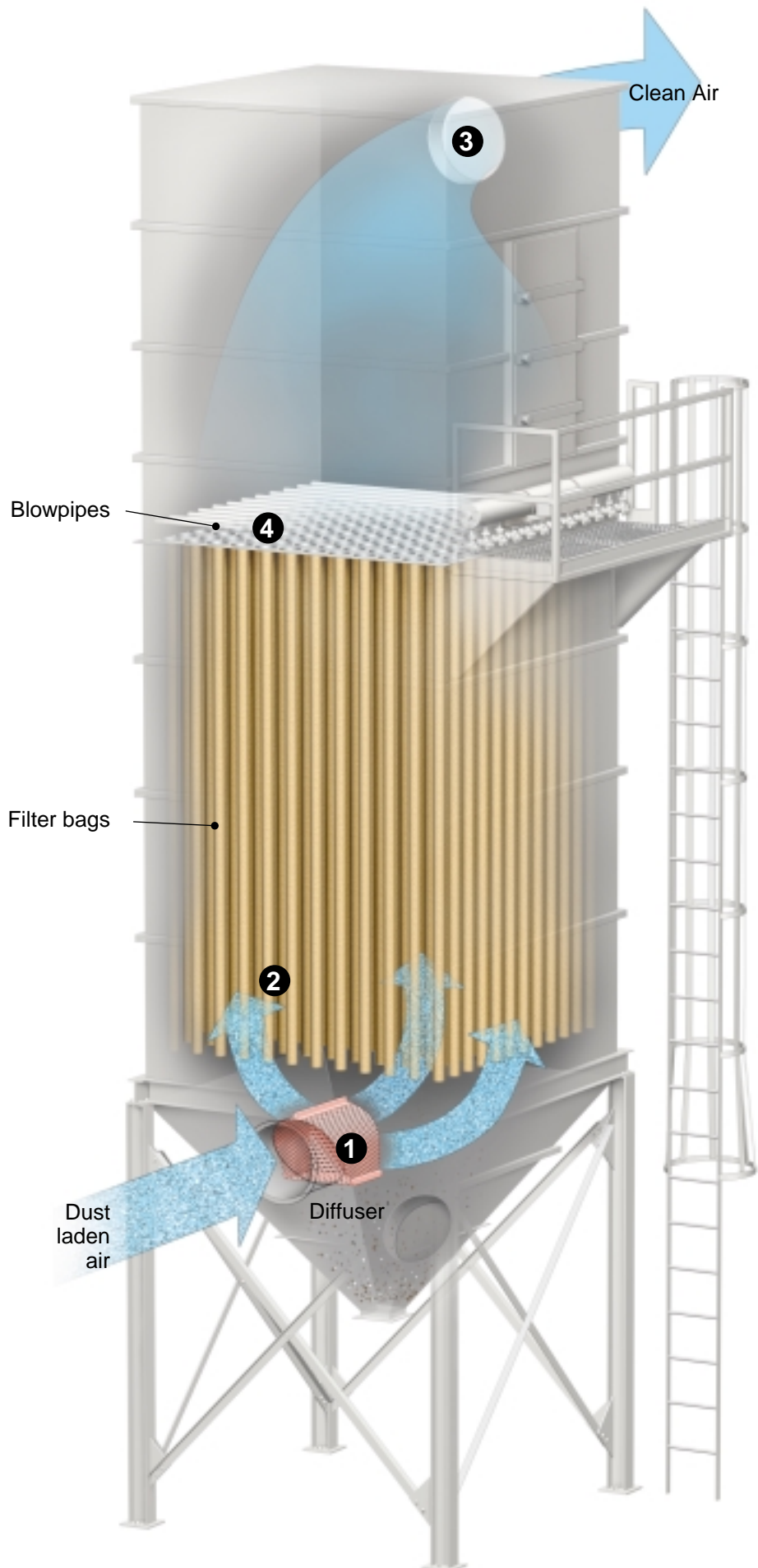

ADVANTAFLOW INLET TECHNOLOGY

Eight years of field and laboratory research revealed that a major problem with dust collector performance is uneven air flow distribution to the filter elements. This uneven distribution is the result of ineffective inlet and diffuser device designs.

Several diffuser designs were investigated: Impingement Plate, Perforated Disc, and Perforated Mail-Box. In all cases the air stream formed two vortex motions. The primary vortex occurs in the filter housing causing very high localized dust laden velocities. A secondary vortex motion is created in the lower part of the hopper, causing high dust re-entrainment and uneven dust discharge.

This condition is the main reason for:

- Abrasion
- Short bag life
- Dust seepage
- High pressure drops
- Reduced air flow capacity
- High cleaning power consumption

Two Solutions

MikroPul R&D arrived at two patented solutions that effectively distribute air flow evenly to the filter bags: The Cascadair hopper inlet and Expandiffuse side inlet, both described at right.

Cascadair and Expandiffuse can be retrofitted to improve the performance of any style or make of pulse-jet collector. The Cascadair can also be used to improve the performance of any dust collector with a hopper inlet including shaker or reverse-air type units.

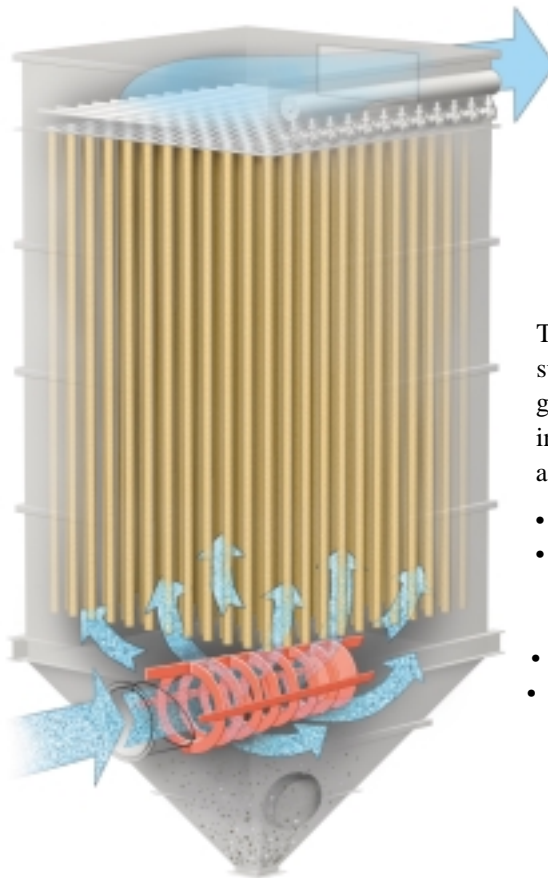

The **Cascadair™** diffuser uses a succession of orifice plates to gradually divert portions of the incoming air in stages. The results achieved:

- Increased bag life
- Lower pressure drop or significantly increased air flow capacity
- Minimum dust re-entrainment
- Overall better filter performance

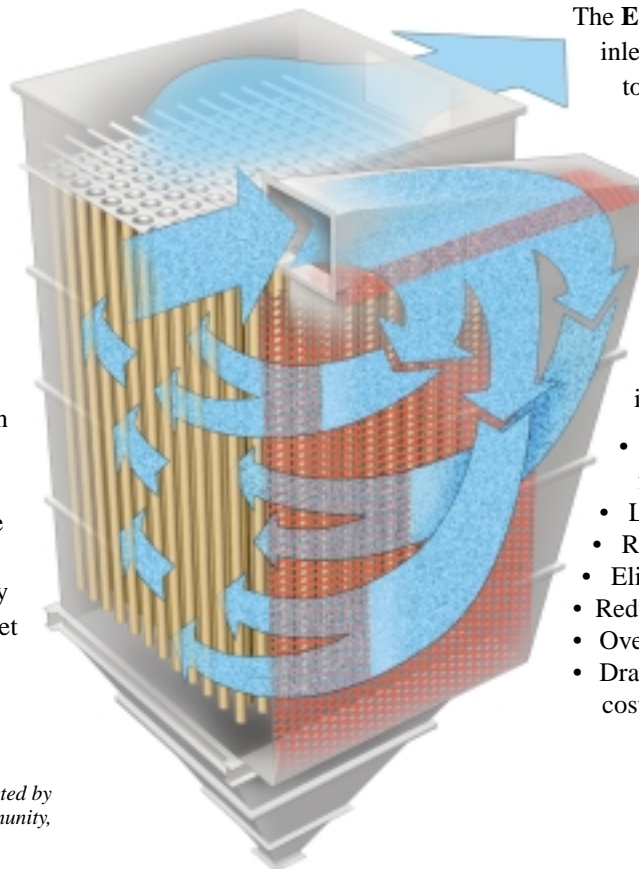

The **Expandiffuse™** is a two stage inlet with diffusers at right angles to each other. Air enters the filter housing from the side of the unit at velocities reduced over 90%. This design improves pulse-jet performance by as much as 40% (or more when combined with MikroPul's Long Bag technology). Benefits include:

- Higher A/C ratio; i.e. greater flow capacity
- Longer bag life
- Reduced pressure drop
- Elimination of dust reentrainment
- Reduction of pulse air consumption
- Overall better filter performance
- Dramatically reduced maintenance costs

MODELS AND APPLICATIONS

Bin Vents

Bin Vent Collectors are used on top of silos and bins or where the bin loading system requires aspiration. MikroPul carries the most common bin vent sizes in stock for quick delivery.

Insertables

Insertable collectors are self-contained units which are integrated into an existing enclosure, allowing dust to be retained at the point at which it is generated.

Common applications: mechanical and pneumatic conveyors, conveyor feed silos, air slides, process machinery, and bins in which powders are fluidized.

Modular Units

Fully assembled Mikro-Pulsaires are ideal for applications requiring filter area generally between 7 and 420 m² of cloth.

Common applications: size reduction machinery, spray dryers, separators, calciners, mixers, packaging machines, conveyors, chemical manufacturers, foundries, grinders, and many other industrial applications.

Large Sectional Units

For large applications, generally above 420 m² cloth area, collectors are provided in prewired sections sized to suit shipping limitations. Subassemblies can be prepared for bolting and/or welding on site.

Common applications: kilns, boilers, dryers, mixers, coke pushing systems, sinter strand systems, furnaces, ladle casters, foundry sources, smelters, and many chemical applications.

Bag Access Styles

Mikro-Pulsaires can be supplied with bag access from either the dirty or clean side of the filter. Choices include:



Bin vent



Preassembled



Large sectional



Top removal

- Bottom removal—ideal for small baghouses or where headroom restraints prevent top removal
- Top removal—access doors on top of unit permit bag maintenance from the clean side, allowing quicker changeout. Leaking bags can be detected rapidly and easily.
- Top removal with walk-in plenum—Also protects mainten-



Top removal with walk-in plenum

ance personnel, media, and valuable, recoverable product from the weather. Work platform and access door provide entry into the clean air plenum.

Cylindrical Units

MikroPul cylindrical collectors are for high vacuum or high pressure applications. Units can be supplied for bag replacement from either the clean or dirty side of the tubesheet. Special designs are available including:

- Housing diameters up to 10 m.
- Abrasion resistant design.
- Quick changeout design where all bags are removed and installed as a unit.
- Heated filter housing by means of heating coils or vessel jacket.
- Explosion relief housing design.
- Housings built to pressure vessel code specifications.

Common applications: spray drying, separating, coal grinding, mixing food manufacturing, car loading, and product receiving from process applications.

Tangential Inlet Model. The MikroPulsaire tangential inlet collector can handle dust loads over 1 kg/m^3 and air-to-cloth ratios of up to 20:1. The inlet acts as a cyclone, causing the air to spin and consequently throw the heavy particulate to the walls and then into the hopper. The fine particles are collected on the filter bags. This design can handle between 1.500 and 100.000+ m^3/h .

Common applications: sander dust, fine lint, cellulose, and grain.

Clean In Place Units

MikroPul offers a patented design for thoroughly cleaning the filter elements without removing them. Features include:

- Total containment for operator and product protection
- Crack and crevice free design
- Sintered stainless steel metal fiber or fabric filter elements
- Full CIP washing and drying sequence control available



Typical custom built process filter

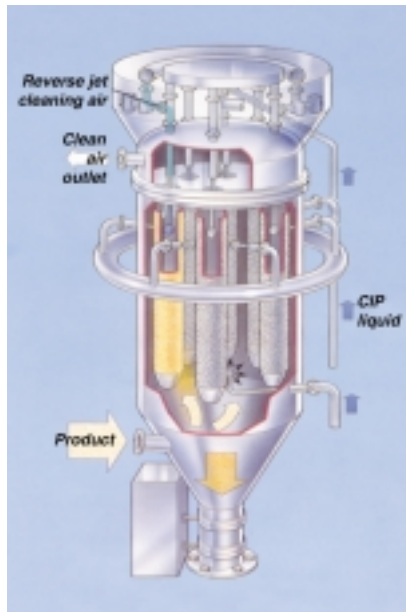

Patented CIP filter design

- Designs to BS 5500, ASME VIII and IX, and VDI 2263
- Pharmaceutical units suitable for FDA validation
- Cleaning by water or organic solvents
- Custom designed to suit each individual application



Dust collector with thermplate heating jacket and ring duct



Steam jet mill filter for titanium dioxide

FILTER MEDIA AND RETAINER ASSEMBLIES

When MikroPul invented the pulse-jet collector, we had to develop the fabric filter bag to make it succeed, and we've been innovating ever since. Filter bag choices include:

- Fabric material and type – an assortment of bag constructions and media fibers are available to suit practically any need.
- Fabric finishes – MikroPul offers a wide variety of finishes and treatments to enhance filtration performance or resist chemical attack.
- Bag length – bags are available in lengths from 0.75 to 8m.

Long-Bag™ Technology

The practical limit for bag length was 3,65 m until MikroPul developed Long Bag technology. Difficulties such as reentrainment, turbulence, unreliable gas distribution, and inability to clean filter continuously, among others, were successfully addressed. Benefits can include:

- Lower pressure drops
- Less pulse cleaning required to maintain a given pressure drop
- Higher filter rates
- Savings in capital, real estate, and maintenance costs

Pleated Filters

MikroPul's Mikro-Pleat™ pleated elements combine the advantages of traditional pulse-jet filter bags and cartridge filters. In many cases, they provide two or more times the cloth area of a conventional filter bag.

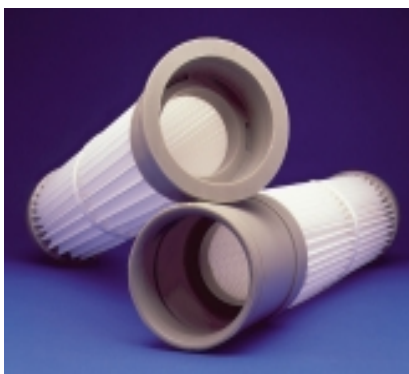

Replacing existing bags with Mikro-Pleat elements can significantly increase baghouse performance without altering the size of the baghouse.

Filter Bag and Retainer Design

MikroPul offers more filter-to-tubesheet connections than anyone. Choices include:

Standard Twist Lock—utilizes separate venturi, retainer assembly, gasket and fold-over bag. A clamp around the outside of the bag, and gasket between the venturi and

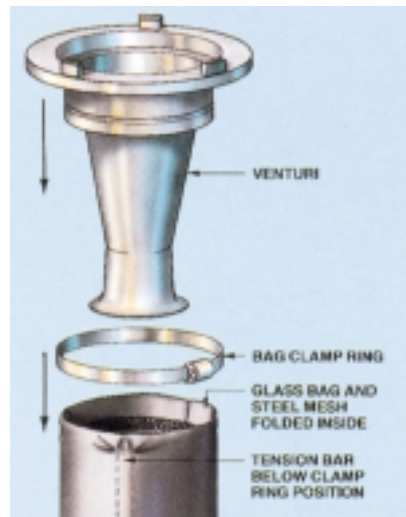

tubesheet provide a leak free seal.

European (clampless)—top removal three-part assembly is very simple to install. The filter bag is put in the tubesheet, and the retainer is slipped inside. The venturi is twist-locked into a die cast collar, which is riveted to the tubesheet.

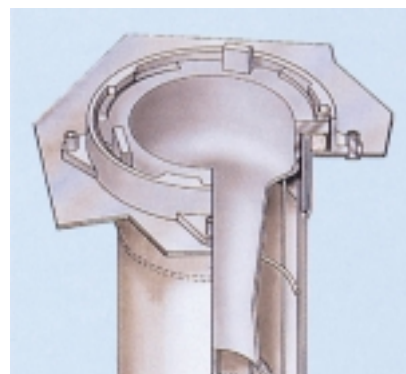

Snap Ring—top removal design utilizes two pieces: the snap ring bag and the one piece venturi/retainer assembly. Installation is done by snapping the bag firmly into the tube-sheet and then placing the venturi/retainer assembly into the bag.

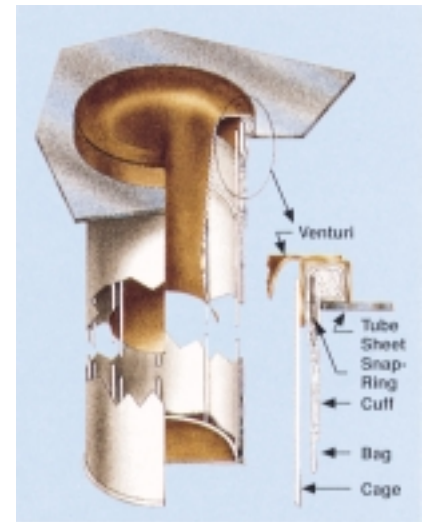

Pop-Top®—These innovative filter bag and cage assemblies save time and money. Changeout is easier (see sequence below) and quicker, yet in most cases they cost no more than standard designs.



Pop-Top bag and cage assemblies are changed out easily and quickly

PULSE TIMERS

Standard Timer

This all solid state sequential timer is supplied as standard equipment for all MikroPul pulse-jet collectors. It is capable of switching 10 independent outputs, allowing it to be used as a 10 position timer. It can also service up to 50 valves (five off each output), as it is supplied for handling more than one dust collector.

Pulse-By-Demand Timer System

This state-of-the-art technology precisely controls filter bag pressure drop (ΔP) in your pulse-jet dust collector. Unlike other “clean-on-demand” timers, which wait until bag ΔP is high to begin pulse cleaning and then overclean to bring the ΔP to a lower level, it senses even small changes in ΔP and responds by providing the precise amount of cleaning needed to control the pressure drop to the level you want.

The result is reduced operating costs and a constant gas flow rate and fan power consumption.

Benefits

- No wide swings in ΔP and air flow
- Reduced compressed air use
- Longer bag life
- Reduced fan power consumption

PulseTRAC™

PulseTRAC integrates diagnostic capabilities with a pulse-by-demand timer. It makes monitoring and maintaining your dust collection equipment easier by continuously monitoring for:

- Loss of compressed air
- Timer failure
- Failed pulse valves
- Pulse solenoid failure
- Leaking bags

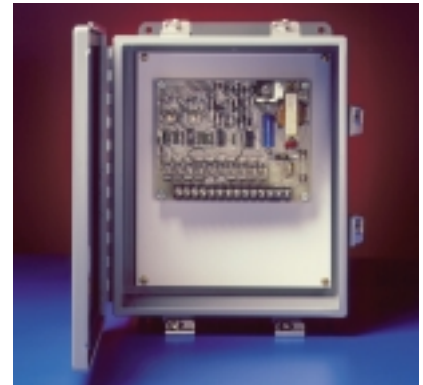

Model 72 timer



PulseTRAC diagnostic and timer control unit

OPTIONS

Every collector is customized for the application. Some of the most common options include:

- Materials of construction to suit your requirements
- Advantaflo inlet technology
- Rotary airlocks
- Explosion proof electricals
- External catwalk
- High temperature design
- Explosion doors meeting NFPA standards
- Inspection windows
- Standlegs and bracing
- Ladder and cage
- Bag grid and/or man grid
- Weather hood over access door
- Pressure gage on header

- Special interior and exterior coatings to your specification
- Pulse-by-demand timers
- PulseTRAC diagnostic system
- Mikro-Charge™ leak detector
- Opti-Coat media conditioning agent
- Gas tight construction
- High pressure construction
- Construction to meet code requirements
- Pulse isolation valves



Rotary airlock

PARTS AND SERVICE

MikroPul backs up our products with reliable and responsive customer support. Call us any time you need help.

Parts

We carry a full line of replacement parts, and keep most-used items on the shelf for immediate shipment. Mikro-Pulsaire parts and accessories available include:

- Filter bags and cages
- Clamps
- Blow pipes
- Diaphragm valves and repair kits
- Solenoid valves and repair kits
- Tubesheets
- Differential pressure gauges
- Timers
- Fans

- Rotary airlocks and replacement vanes
- Access doors
- Door seals
- Explosion vents
- Vent valves
- Acoustic horns
- Hopper vibrators
- Vacuum systems
- Screw conveyors

Services

MikroPul provides an array of services to help you select, install, operate, and maximize your equipment investment. Services include:

- Clean air preparation program
- Inspections
- Collector refurbishing



- Collector rebuilding
- Converting old collectors to new technology
- Preventive maintenance programs
- Bag testing
- Maintenance seminars
- Erection services

MikroPul Global Network

Americas

MikroPul
20 Chatham Road
Summit, NJ 07901
USA
Tel: 908-598-1100
Fax: 908-598-1302
info@mikropul.com

MikroPul Pittsburgh
Steel, Foundry, and Non-Ferrous Metals
2591 Wexford-Bayne Road, Suite 202
Sewickley, PA 15143
USA
Tel: 724-934-3910
Fax: 724-934-3934
pittsburgh@mikropul.com

MikroPul Canada, Inc.
245 Matheson Blvd. E., Unit # 10
Mississauga, Ontario L4Z 3C9
CANADA
Tel: 905-712-0722
Fax: 905-712-0027
info@ca.mikropul.com

MikroPul, S de RL de CV
Av. Lomas Verdes No. 480-302B
Col. Lomas Verdes
CP 53120 Naucalpan
Edo. de Mexico
Tel: 52-5-343-8224
Fax: 52-5-344-5081
info@mx.mikropul.com

Europe

MikroPul GmbH & Co. KG
Welsersstrasse 9-11
D-51149 Cologne
GERMANY
Tel: +49-2203-9391-0
Fax: +49-2203-9391-293
info@mikropul.de

Filter-Media Div. of MikroPul France S.A.
15 Quai Tilsitt
69002 Lyon
FRANCE
Tel: +33-04-72-56-90-10
Fax: +33-04-78-37-64-48
mikropul@easynet.fr

MikroPul Limited
Chadwick House
Birchwood Park
Warrington, Cheshire WA3 6AE
UNITED KINGDOM
Tel: +44-01925-849220
Fax: +44-01925-849221
info@uk.mikropul.com

Asia/Pacific

MikroPul Australia Pty Ltd
1 Toohey Road
Wetherill Park, NSW 2164
AUSTRALIA
Tel: 61-2-9756-2933
Fax: 61-2-9756-3120
mikropul.syd@tpg.com.au

Africa

MikroPul (Pty.) Limited
Evapark Block B
Cnr DF Malan Dr. & Judges Ave.,
Cresta, Johannesburg
SOUTH AFRICA
Tel: +27-(11)-478-0456
Fax: +27-(11)-478-0371
sales@mikropul.co.za

www.mikropul.com



A member of Beacon Industrial Group