

ROLLER COMPACTORS FOR THE PHARMACEUTICAL AND CHEMICAL INDUSTRIES

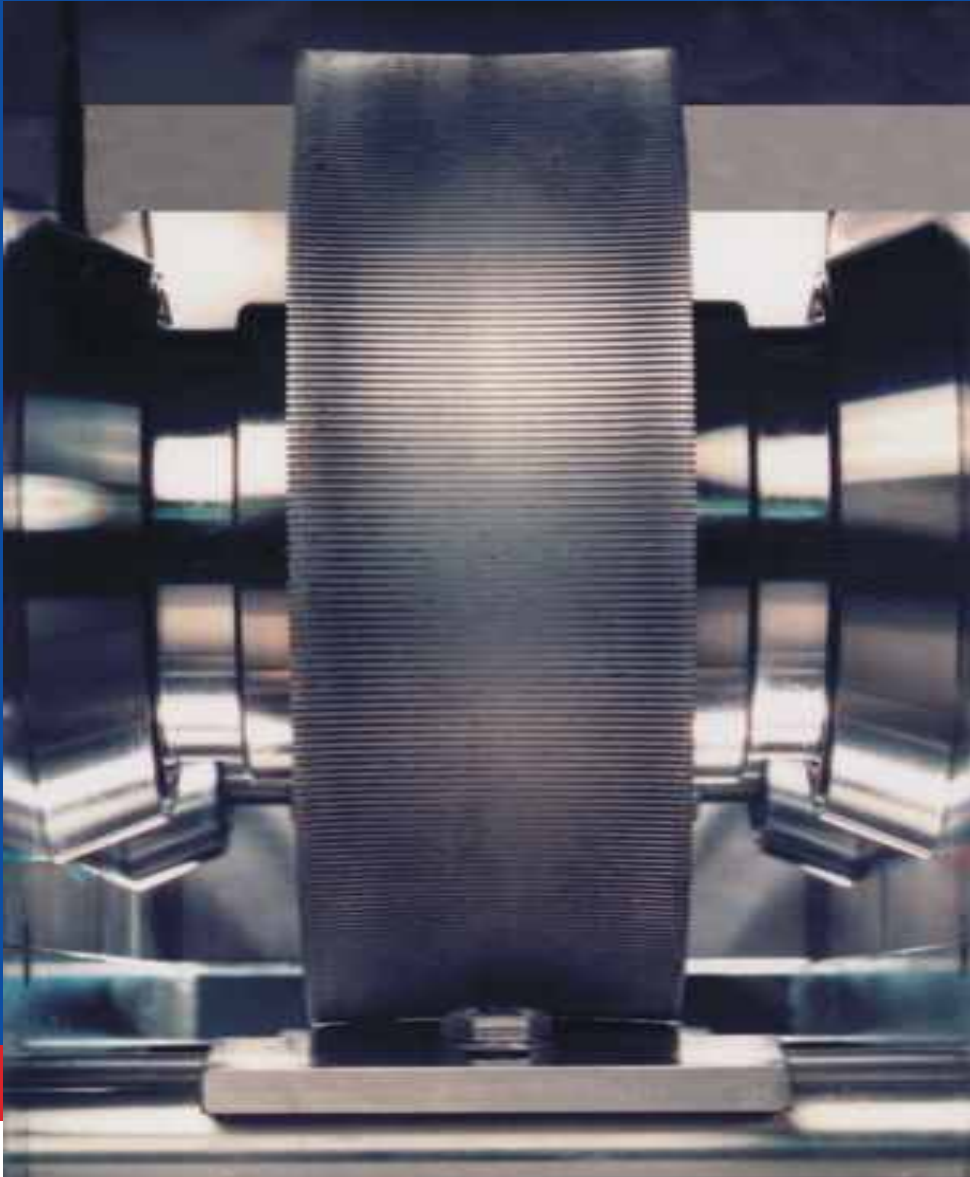

HOSOKAWA BEPEX GmbH

Compaction and Briquetting Densification and Particle Sizing

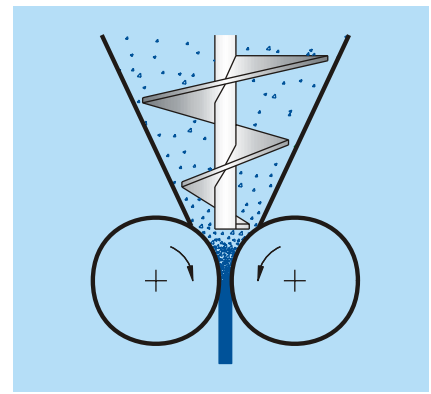

Compaction

Powder is compressed into a solid form called "flakes". Compressing the powder into flakes increases the bulk density of the material for the final product.

Dry Granulation

The "flakes" produced by compaction are gently milled to the required particle size distribution (PSD) as required by the process. Sieving or classification can also be performed to achieve a tighter distribution. Typically in the chemical industry, a PSD of 1 - 3 mm or larger is standard. For capsule filling or tableting in the pharmaceutical industry, the PSD range is typically 200 μm - 800 μm or 200 μm - 1000 μm .



Compacted flakes and final granules

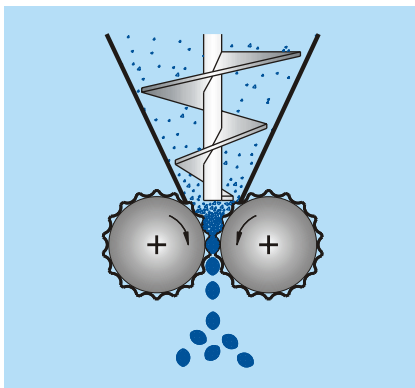

Briquetting

Briquetting processes utilize specially made compaction rolls enabling production of a variety of sizes and shapes. Typical examples include:

- Pillow shapes
- Almond shapes
- Stick shapes

Synchronized counter-rotating rolls and very tight tolerances ensure a consistent end-product.

Compaction Benefits:

- Ensures good flow properties
- Increases bulk density
- Particle size distribution can be pre-selected and controlled
- Low energy consumption
- Minimal product heating
- Dust free processing
- Good dosing properties
- Consistent results



A wide range of sizes and shapes

Powder Control Technology

The Exact Particle Size Your Product Needs

Dry Granulation System Layout

The typical dry granulation system includes:

- Compaction
- Milling (granulation)
- Sieving (optional)
- Recycle of out-of-spec material (optional)

These systems are designed as closed systems and offer dust free processing. Gas tight systems are also available.

The granulation system has a low energy requirement ensuring gentle processing with minimal temperature increase.

Design options include extensive automation to reduce production costs and operator requirements.

Various grades of stainless steel construction materials are available upon request.

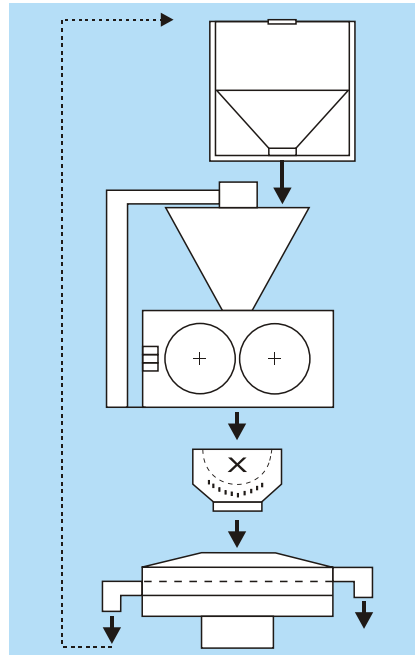

Briquetting System Layout

Forming powder into briquettes requires a high press force, but typically binders are not required. After briquetting, a screening deck is used to remove any undersized particles. These fines are then recycled back into the machine for further briquetting.

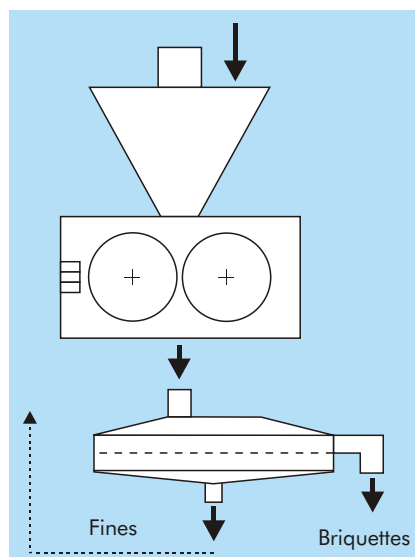

PHARMAPAKTOR®

Technology for Pharmaceutical Production



Model "L"

This design enables easy cleaning and inspection of the machine.

The compaction head is designed for easy removal of the rolls.



The Pharmapaktor and the Flake Crusher are designed for dust free processing. A gas tight design is also available upon request. A clear window enables visual confirmation of the process.

The feed screw and feed hopper assembly can easily be lifted and rotated without special lifts or tools.

Black & White Design

In the ideal pharma production environment, the process area and the mechanical area are separated. All motors, electrical instruments and mechanical drive components are located in a separate room, offering enhanced safety for the operators and compliance with cGMP practices.



Stainless steel process wall



- Pneumatic Transport System
- Pharmapaktor
- Flake Crusher Mill

Quick release clamps, plugs and tri-clover ferrules make disassembly, cleaning and assembly fast, easy and safe.

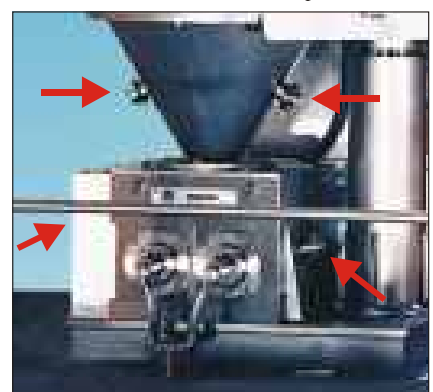

WIP/CIP nozzles for rinsing/cleaning of the pre-densification assembly and the roll assembly.

Details

What Makes It Work



Vacuum de-aeration

Highly aerated products can be de-aerated with a vacuum system. This process enables the pre-densification feeder to operate more efficiently and dramatically increases the overall throughput of the machine.

Either the central house vacuum system or a dedicated vacuum pump can be used.

The air, which is removed, should be filtered. Filtering eliminates dusting concerns and ensures a safe working environment for the operators when toxic formulations are processed.

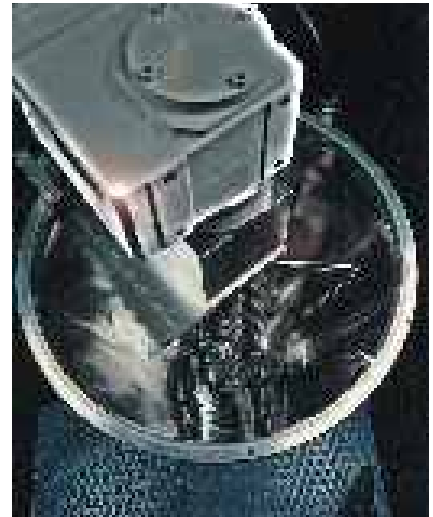

Perfect Finishes:

For the feed hopper, higher grade polishes are used to minimize bridging and material binding.

These polish levels also offer ease in cleaning and helps prevent cross-contamination of products.

We know what the pharma industry needs:

- Materials of construction: 304/304L, 316/316L/316Ti or Hastelloy
- Glass bead finish
- Polishes from 1.2 Ra to 0.3 Ra
- Electropolishing
- Material certifications
- Calibration services
- GMP and FDA approved materials
- IQ, OQ & FAT service available
- Automation
- Direct measurements
- Visualization

Design Details:

- Electronic & direct press force measurement
- Automatic press force control
- Roll cooling systems available
- Adjustable roll gap
- Temperature measurements in nip region



Machines For All Capacities and System Requirements



System Design and Automation

Our scope of supply is not limited to machines. We also offer complete systems and system accessories such as controls, FAT's, calibration, system commissioning and operator training.

Process guarantees are available.

Our engineering staff can custom design cGMP and OSHA compliant systems for existing rooms.

The Complete Product Line:

The throughput of a compaction system is dependent on the bulk density of the feed material. The roll speed is variable to match capacity requirements and allows fine tuning without affects to the quality of the products.

The Accessories:

To ensure high yields of the compacted flakes, we offer both conical and horizontal compression mills. Further information about our line of mills is available in our "Size Reduction Technology" brochure.



Technical Data:

Type	L 200/30 P	L 200/50 P	K 200/50	K 200/100	K 300/200
Press force	100 kN	150 kN	150 kN	200 kN	300 kN
Roll diameter	200 mm	200 mm	200 mm	200 mm	300 mm
Roll width	30 mm	50 mm	50 - 150 mm	50 - 150 mm	150 - 300 mm
Drive power	1,5 kW	4 kW	4 kW	15 kW	30 kW
Roll cooling	no	no	yes	yes	yes
Direct press force measurement	yes	yes	yes	yes	yes
Automatic press force control	yes	yes	yes	yes	yes
Adjustable roll gap	no	no	yes	yes	yes
Dust free construction	yes	yes	yes	yes	yes
Gas tight construction	yes	yes	yes	yes	yes
WIP/CIP design	yes	yes	yes	yes	yes

R & D, Pilot Plant or Production

Our equipment will fit your needs !

For Small Quantities

Only small quantities are typically available for R&D and lab use. All operating parameters and information can be scaleable to the larger production sized machines.

For R&D and lab use we offer the standard Pharmapaktor with the following modifications or features:

- Smaller roll width
- Lower roll speeds
- Smaller hopper capacity
- Full instrumentation and automation



The Bepex Test Center

Our test center specializes in process optimization and new material testing.

Experienced and knowledgeable staff members work together with our customers to ensure their specific testing requirements are met.

Our test center is equipped with compaction equipment as well as mixing, sifting, milling and all sorts of analytical lab equipment for measuring bulk density, particle size, moisture content, strength and hardness of products.



PHARMAPAKTOR - mobile lab unit



BEPEX Agglomeration Technology

We bring your powder into shape



HOSOKAWA BEPEX GmbH

P.O. Box 1152
D-74207 Leingarten / Germany
Tel.: 0049 (0)7131 / 907 - 0
Fax: 0049 (0)7131 / 907 - 301

E-Mail:
compaction@bepex.hosokawa.com

Delivery address:
Daimlerstr. 8
D-74211 Leingarten / Germany

The BEPEX Technologies

Machines and complete plants for

- Compaction
- Briquetting
- Granulation
- Size reduction
- Pelletizing
- Extrusion
- Spheronization



HOSOKAWA BEPEX GmbH

Hosokawa Bepex GmbH is a member of the Hosokawa Micron Group, responding to global needs through emphasis on materials science and engineering. The Group is an international provider of equipment and technology for powder and particle processing, plastics processing and confectionery products. The Group maintains facilities for research, engineering, manufacturing and service in each of the world's major industrial markets.

Internet
<http://www.hosokawamicron.com>